

Manual Hoist HCB series

Best selling in USA

- Compact design, all steel construction, light handpull.
- Heat treated low-wear, corrosive resistant chain.
- Drop-forged hooks designed to bend slowly to warn of overloads.
- **Conforms to CE safety standard.**

IMPORTANT:

Before installation, see maintenance and operation manual for additional warnings and precautions. Do not use in explosive environment.



HCB100



HCB50



HCB30



HCB10

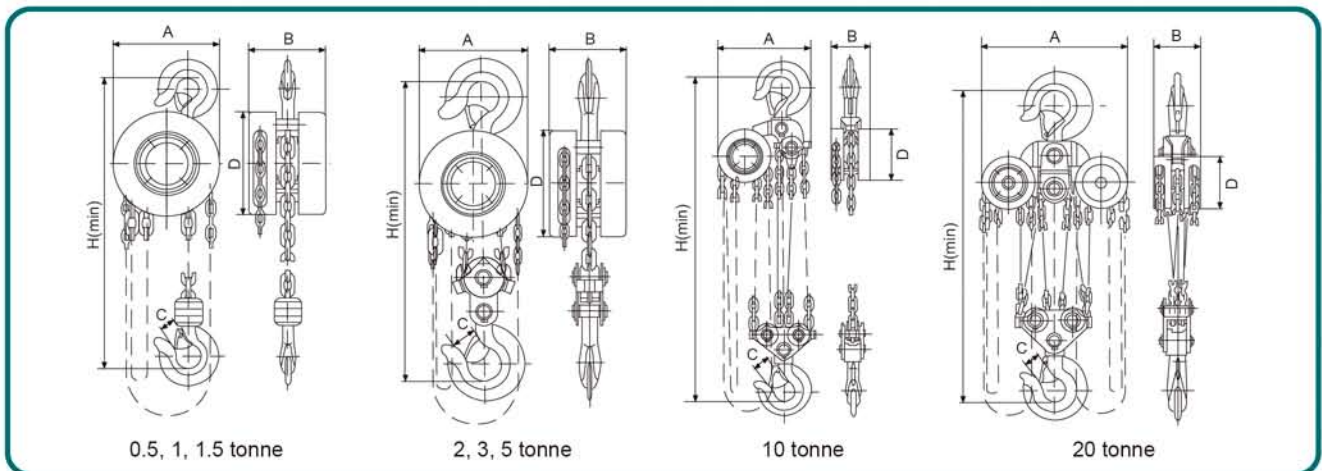

i-Lift No.	2110601	2110602	2110603	2110604	2110605	2110606	2110607	2110608
Model	HCB05	HCB10	HCB15	HCB20	HCB30	HCB50	HCB100	HCB200
Rated Capacity (tonne)	0.5	1	1.5	2	3	5	10	20
Standard Lifting Height (m)	2.5 3	2.5 3	2.5 3	2.5 3	3 5	3 5	3 5	3 5
Test Load (KN)	6.3	12.5	18.8	25	37.5	62.5	125	250
Effort to Rated Capacity (N)	160	310	360	320	360	400	430	430
No. of Load Chain Falls	1	1	1	2	2	2	4	8
Min. Distance between Hooks H (mm)	280	300	360	380	470	600	730	1000
Diameter of Load Chain (mm)	ø6x18	ø6x18	ø8x24	ø6x18	ø8x24	ø10x30	ø10x30	ø10x30
Dimensions	A (mm)	142	142	178	142	178	210	580
	B (mm)	130	122	139	122	139	162	189
	C (mm)	24	28	32	34	38	48	82
	D (mm)	142	142	178	142	178	210	580
Net Weight (kg)	9 9.8	9.2 10	14.5 15.3	12 13.5	19.2 21.7	32 35	62 65	140 146
Gross Weight (kg)	9.4 10.2	9.6 10.4	14.9 15.9	12.6 14	19.8 22.3	33 36	64 77	142 172
Extra Weight Per Meter of Extra Lift (pcs)	1.65	1.65	2.3	2.5	3.7	5.2	9.6	19.2

Note: In addition to the standard lift height, we accept up to 12m lifting height.